

Single-mode 2.5Gbps Transmitter / Receiver

Features

Transmitter :

- 2 x 10 pins, 2 x 8 pins metal case / plastic case
- 1310nm, 1550nm LD transmitter with automatic power control
- AC coupled LVPECL compatible data input and output
- Single 3.3V power supply



Receiver :

- 2 x 10 pins, 2 x 8 pins metal case / plastic case
- InGaAs PIN detector
- Receiver loss of signal output
- Single 3.3V power supply



Specifications

Parameter	Symbol	Min.	Typ.	Max.	Unit
Transmitter					
Data Rate (NRZ)	B	-	2500	-	Mb/s
Optical Output Power (avg.) ^{(1) (2) (3)}					
-1	P_o	-12	-	-6	dBm
-2	P_o	-6	-	0	dBm
Extinction Ratio	ER	8.2	-	-	dB
Optical Wavelength					
1310nm FP LD	λ_c	1260	1310	1360	nm
1310nm DFB LD	λ_c	1290	1310	1330	nm
1550nm FP LD	λ_c	1490	1550	1610	nm
1550nm DFB LD	λ_c	1530	1550	1570	nm
Spectral Width (RMS, -20dB)					
1310nm FP LD	$\Delta\lambda$	-	1.0	2.0	nm
1550nm FP LD	$\Delta\lambda$	-	1.0	2.5	nm
Side Mode Suppression Ratio					
1310nm DFB LD	SMSR	30	40	-	dB
1550nm DFB LD	SMSR	30	40	-	dB
Output Rise Time (20-80%)	t_r	-	-	180	ps
Output Fall Time (20-80%)	t_f	-	-	180	ps
Data Differential Input Voltage ⁽⁶⁾	V_i	500	-	2400	mV _{p-p}
Supply Voltage	V_{cc}	2.97	3.3	3.63	V
Supply Current	I_{cc}	-	-	120	mA

Single-mode 2.5Gbps Transmitter / Receiver

Parameter	Symbol	Min.	Typ.	Max.	Unit
Receiver					
Data Rate (NRZ)	B	-	2500	-	Mb/s
Optical Input (avg.) Sensitivity ^{(1) (5)}	P _{IN}	-	-	-18	dBm
Saturation	P _{SAT}	-3	0	-	dBm
Optical Wavelength	λ	1100	-	1600	nm
Output Rise Time (20-80%)	t _r	-	-	175	ps
Output Fall Time (20-80%)	t _f	-	-	175	ps
Data Differential Output Voltage ⁽⁶⁾	V _o	600	-	1200	mV _{p-p}
LOS Deasserted Power Level (avg.)	P _A	-	-	-18	dBm
LOS Asserted Power Level (avg.)	P _D	-28	-	-	dBm
LOS Hysteresis	P _{HYS}	0.5	3	-	dB
LOS Output Voltage	V _{LOS-OL}	0	-	0.4	V
	V _{LOS-OH}	2.4	-	V _{CC}	
Supply Voltage	V _{CC}	2.97	3.3	3.63	V
Supply Current	I _{CC}	-	-	120	mA

Notes :

- (1) With 0.275 NA, 9/125μm fiber.
- (2) Driven with a differential signal.
- (3) Class 1 eye safe per FDA and IEC.
- (4) Transmitter eye mask diagram is compliant to ITU-T G.957 Eye Diagram.
- (5) 2²³ -1 PRBS, BER= 10⁻¹⁰.
- (6) Compatible with LVPECL logic levels.
- (7) The transmitter output should not be viewed directly.

Absolute Maximum Ratings

Parameter	Min.	Max.	Unit
Operating Temperature	-40	85	°C
Storage Temperature	-40	100	°C
Lead Soldering Limits	-	240/10	°C /sec
Supply Voltage	-0.2	4	V

Single-mode 2.5Gbps Transmitter / Receiver

Ordering Information

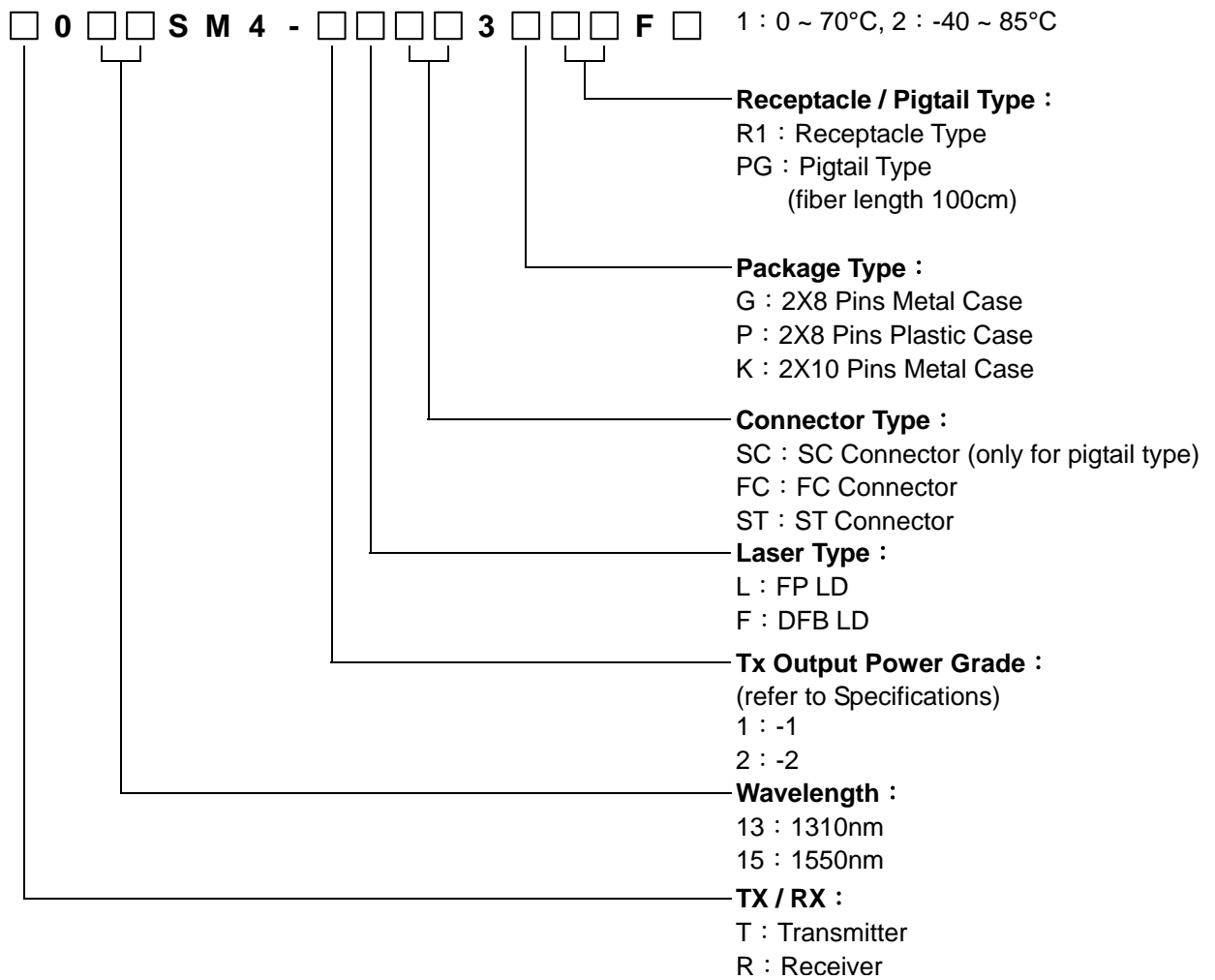

Single-mode 2.5Gbps Transmitter / Receiver

Outline Drawing (2X8 Pins Package)

2X8 Pins Plastic Case :

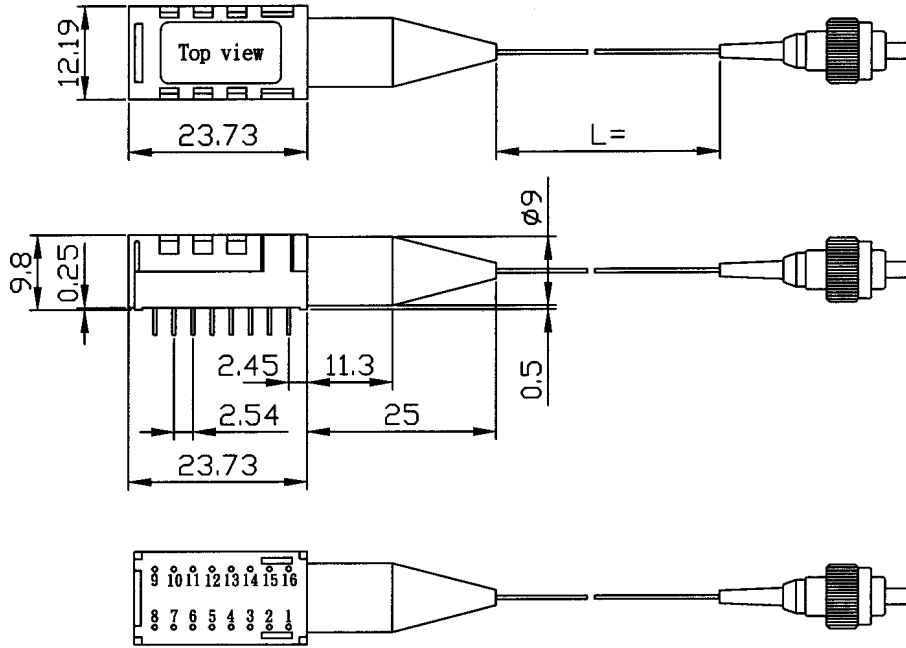

UNIT : mm

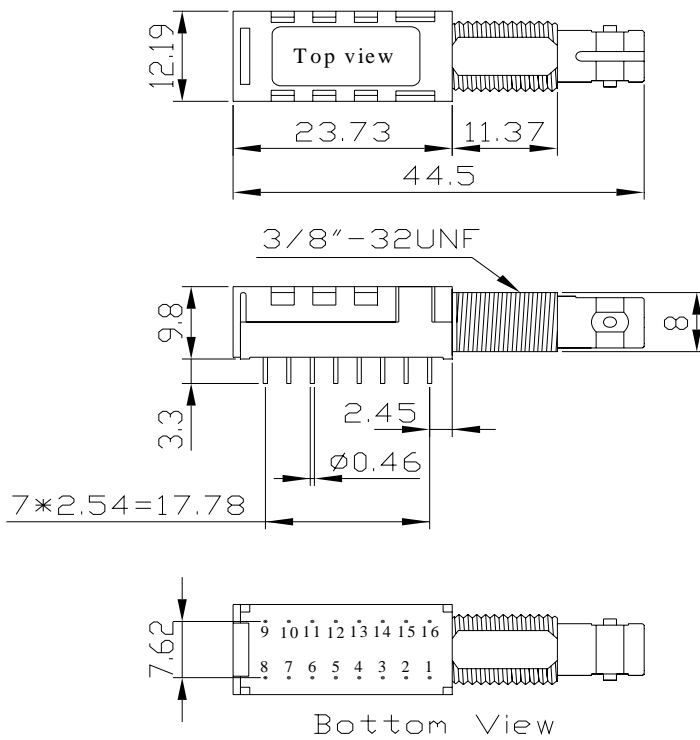

Unit:mm

Single-mode 2.5Gbps Transmitter / Receiver

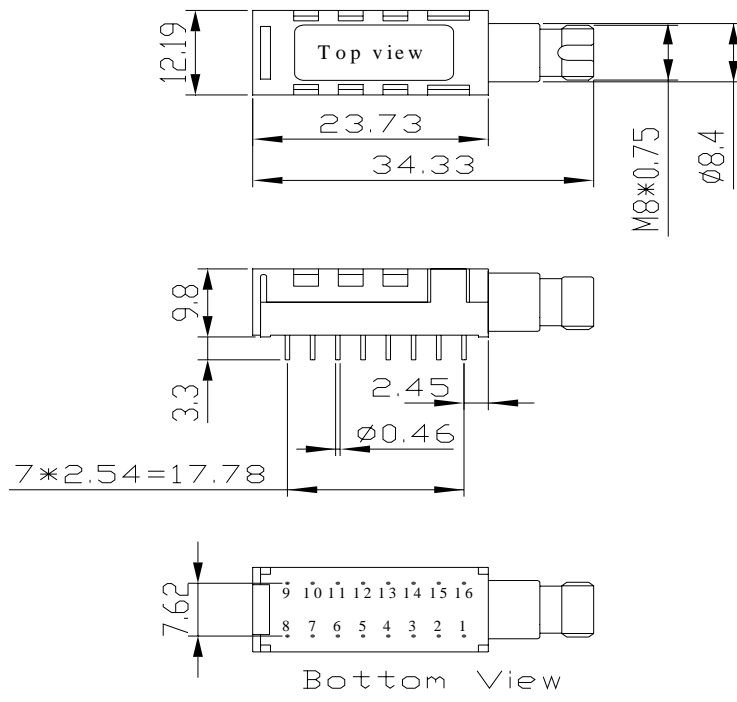

Unit:mm

2X8 Pins Metal Case :

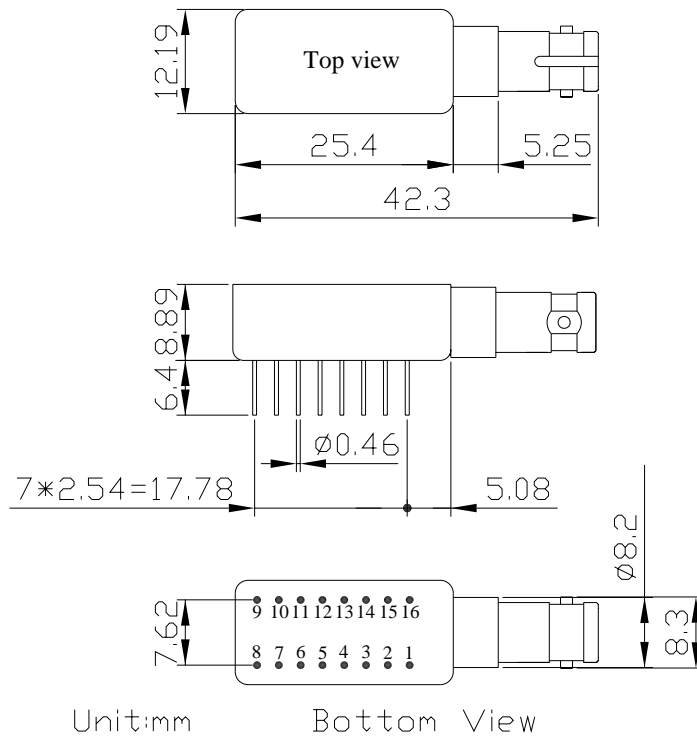

Unit:mm

Bottom View

UNIT : mm

Single-mode 2.5Gbps Transmitter / Receiver

Pin-out Description (2X8 Pins Package)

Transmitter Pin Assignment

Pin No.	Description
1	No Connection ^(Note)
2	No Connection
3	Vee (Ground)
4	Vee (Ground)
5	Vee (Ground)
6	Vee (Ground)
7	No Connection
8	No Connection ^(Note)
9	No Connection ^(Note)
10	Vee (Ground)
11	Vcc (Supply Voltage)
12	Vcc (Supply Voltage)
13	Vee (Ground)
14	Data In
15	Data In (Inverted)
16	No Connection ^(Note)

Receiver Pin Assignment

Pin No.	Description
1	No Connection ^(Note)
2	Data Out (Inverted)
3	Data Out
4	Vcc (Supply Voltage)
5	Vcc (Supply Voltage)
6	Vcc (Supply Voltage)
7	Vee (Ground)
8	No Connection ^(Note)
9	No Connection ^(Note)
10	No Connection
11	Vee (Ground)
12	Vee (Ground)
13	Vee (Ground)
14	No Connection
15	LOS
16	No Connection ^(Note)

Note : Metal case version Pin1, Pin8, Pin9 and Pin16 internal connect to case.

Single-mode 2.5Gbps Transmitter / Receiver

Outline Drawing (2X10 Pins Package)

2X10 Pins Metal Case :

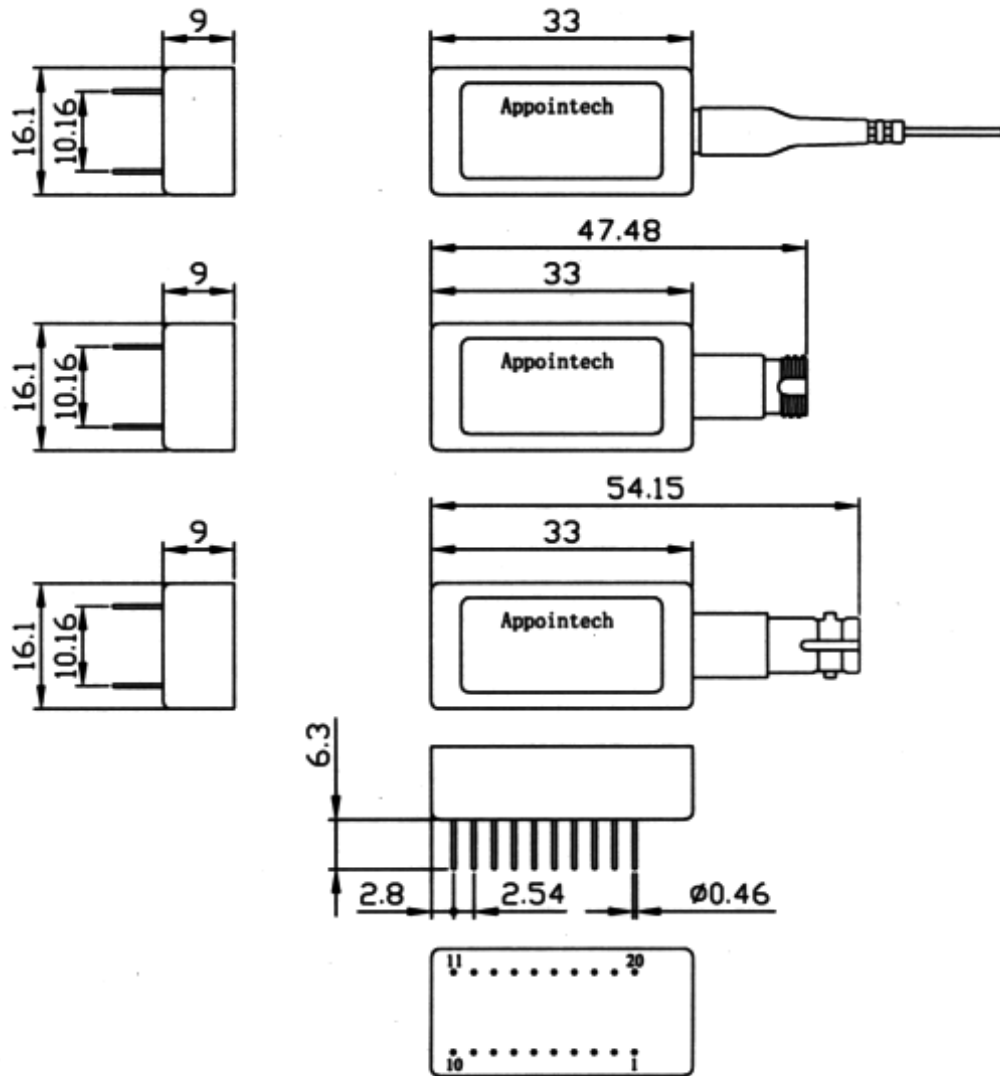

UNIT : mm

Single-mode 2.5Gbps Transmitter / Receiver

Pin-out Description (2x10 Pins Package)

Transmitter Pin Assignment

Pin No.	Description
1	No Connection
2	No Connection
3	No Connection
4	No Connection
5	Vee(Ground)
6	Vcc(Supply Voltage)
7	Transmitter Disable ^(Note)
8	Vcc(Supply Voltage)
9	Vcc(Supply Voltage)
10	No Connection
11	Vee(Ground)
12	Vcc(Supply Voltage)
13	Vee(Ground)
14	Vee(Ground)
15	Data In (Inverted)
16	Data In
17	No Connection
18	Vcc(Supply Voltage)
19	No Connection
20	No Connection

Receiver Pin Assignment

Pin No.	Description
1	No Connection
2	No Connection
3	No Connection
4	No Connection
5	No Connection
6	Vee(Ground)
7	Data Out
8	Vee(Ground)
9	Data Out (Inverted)
10	No Connection
11	Vcc(Supply Voltage)
12	No Connection
13	Vee(Ground)
14	LOS
15	Vee(Ground)
16	Vee(Ground)
17	No Connection
18	No Connection
19	No Connection
20	No Connection

Note : Input TTL Logic Low Level to Switch Laser "ON".
 Input TTL Logic High Level to Switch Laser "OFF".

Appointech, Inc.

6F-2, NO.192 Tung-Kuan Rd.,
 Hsinchu, Taiwan, R.O.C.
 TEL : 886-3-573-8478
 FAX : 886-3-573-8441
 E-mail : sales@appointech.com
<http://www.appointech.com>