

Multi-mode 155Mbps Transmitter / Receiver

Features

Transmitter :

- 2 x 10 pins, 2 x 8 pins metal case / plastic case
- ST, SC, or FC connection
- 850 VCSEL transmitter with automatic power control
- AC or DC coupled LVPECL or PECL compatible data input and output
- Single 3.3V or 5V power supply



Receiver :

- 2 x 10 pins, 2 x 8 pins metal case / plastic case
- ST, SC, or FC connection
- GaAs PIN-TIA
- PECL or TTL signal detect output
- Single 3.3V or 5V power supply



Specifications

Parameter		Symbol	Min.	Typ.	Max.	Unit
Transmitter						
Data Rate (NRZ)		B	2	155	-	Mb/s
Optical Output Power (avg.) ^{(1) (2) (3)}		P _o	-9	-	-3	dBm
Extinction Ratio		ER	9	-	-	dB
Optical Wavelength		λ_C	830	850	860	nm
Spectral Width (RMS, -20dB)		$\lambda\Delta$	-	-	0.85	nm
Output Rise Time (20-80%)		t _r	-	-	0.26	ns
Output Fall Time (20-80%)		t _f	-	-	0.26	ns
Data Input ⁽⁶⁾	DC Coupled	V _{IL} V _{IH}	V _{CC} -1.810 V _{CC} -1.165	- -	V _{CC} -1.475 V _{CC} -0.880	V V
	AC Coupled (Differential)	V _I	0.25	-	1.6	V
Supply Voltage		V _{CC}	3.10 4.75	3.3 5.0	3.50 5.25	V
Supply Current		I _{CC}	-	-	110	mA

Multi-mode 155Mbps Transmitter / Receiver

Parameter		Symbol	Min.	Typ.	Max.	Unit
Receiver						
Data Rate (NRZ)		B	2	155	-	Mb/s
Optical Input (avg.) Sensitivity ^{(1) (5)}		P _{IN}	-	-	-32	dBm
Saturation		P _{SAT}	-3	0	-	dBm
Optical Wavelength		λ	770	850	860	nm
Output Rise Time (20-80%)		t _r	-	-	0.4	ns
Output Fall Time (20-80%)		t _f	-	-	0.4	ns
Data Output ⁽⁶⁾	DC Coupled	V _{OL} V _{OH}	V _{CC} -1.840 V _{CC} -1.045	- -	V _{CC} -1.62 V _{CC} -0.88	V V
	AC Coupled (Differential)	V _I	0.6	-	1.8	V
Signal Detect Asserted (avg.)		P _A	-	-	-17	dBm
Signal Detect Deasserted (avg.)		P _D	-27	-	-	dBm
Hysteresis		P _{HYS}	-	2	-	dB
Supply Voltage		V _{CC}	3.10 4.75	3.3 5.0	3.50 5.25	V
Supply Current		I _{CC}	-	-	100	mA

Notes :

- (1) With 0.275 NA, 62.5/125μm fiber.
- (2) Driven with a differential signal.
- (3) Class 1 eye safe per FDA and IEC.
- (4) Eye mask diagram is compliant to IEEE802.3z Eye Diagram.
- (5) 2⁷ -1 PRBS, BER= 10⁻¹².
- (6) Compatible with LVPECL and PECL logic levels.
- (7) The transmitter output should not be viewed directly.

Absolute Maximum Ratings

Parameter		Min.	Max.	Unit
Operating Temperature	-1	0	70	°C
	-2	-40	85	°C
Storage Temperature		-40	100	°C
Lead Soldering Limits		-	240/10	°C /sec
Supply Voltage	5V	-0.2	7	V
	3.3V	-0.2	4	V

Multi-mode 155Mbps Transmitter / Receiver

Ordering Information

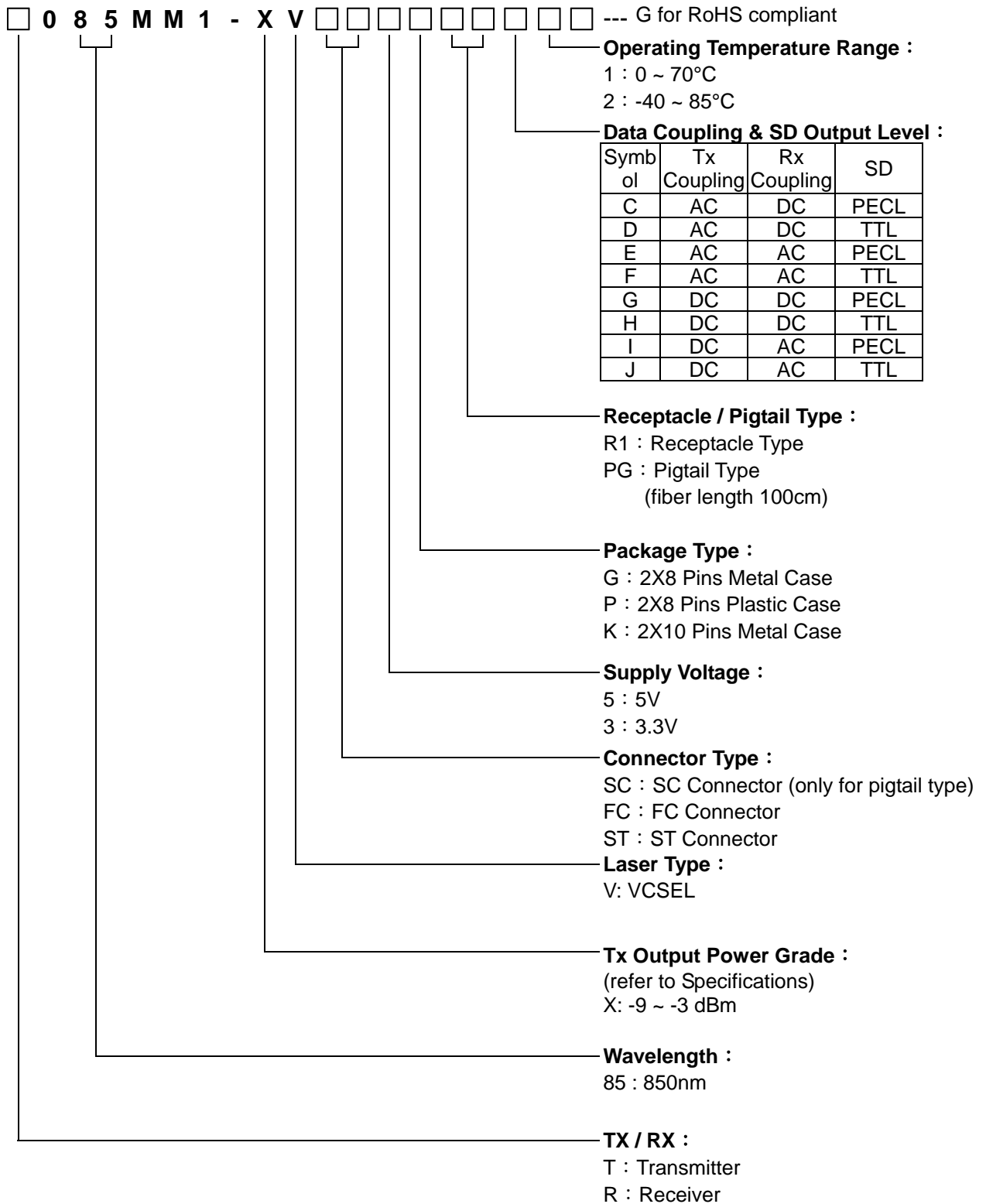

Multi-mode 155Mbps Transmitter / Receiver

Outline Drawing (2X8 Pins Package)

2X8 Pins Plastic Case :

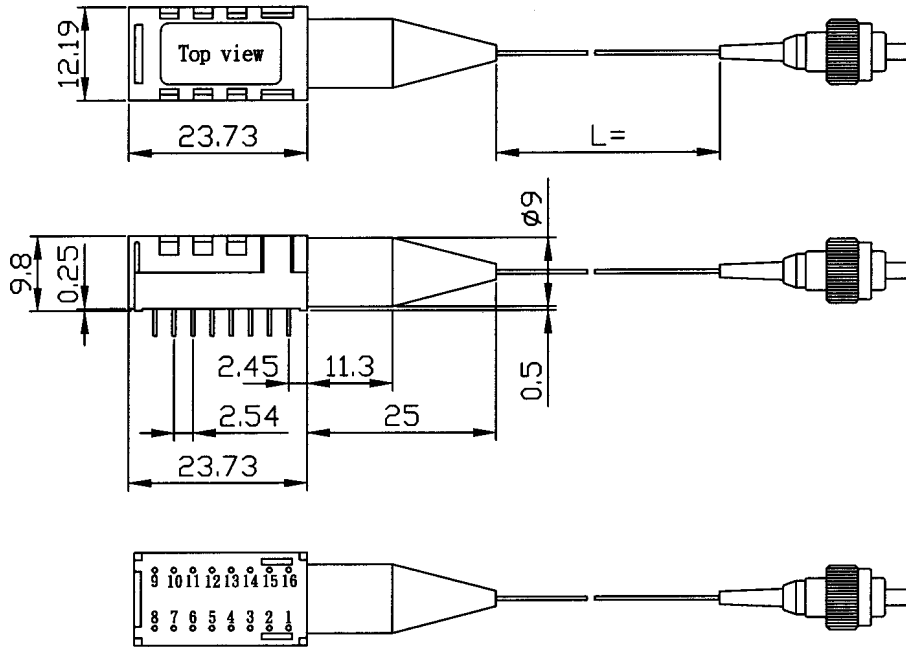

UNIT : mm

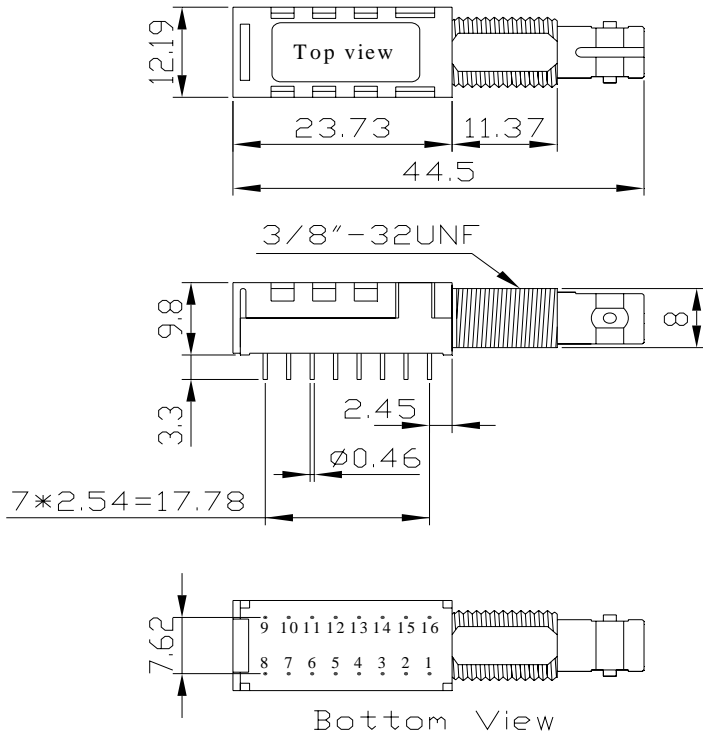

Unit:mm

Multi-mode 155Mbps Transmitter / Receiver

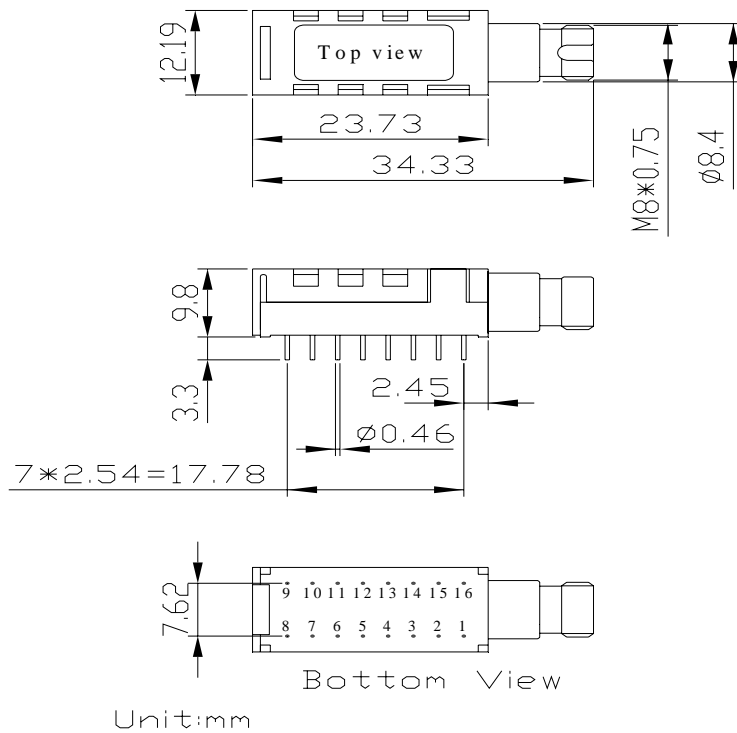

2X8 Pins Metal Case :

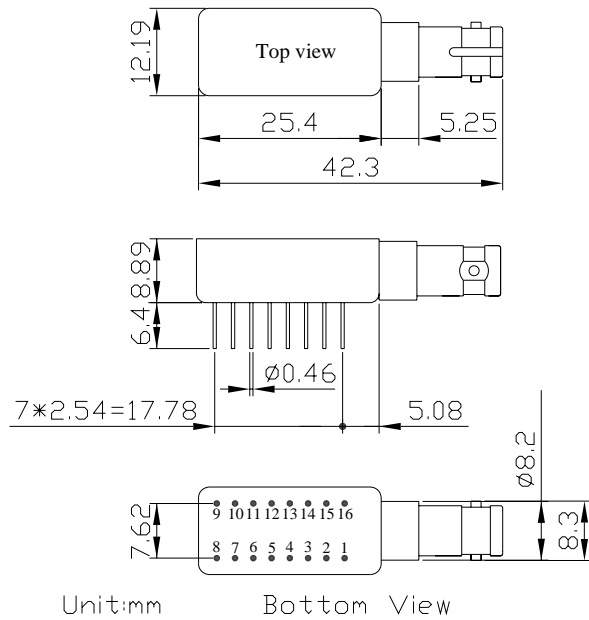

UNIT : mm

Multi-mode 155Mbps Transmitter / Receiver

Pinout Description (2X8 Pins Package)

Transmitter Pin Assignment

Pin No.	Description
1	No Connection ^(Note)
2	No Connection
3	Vee (Ground)
4	Vee (Ground)
5	Vee (Ground)
6	Vee (Ground)
7	No Connection
8	No Connection ^(Note)
9	No Connection ^(Note)
10	Vee (Ground)
11	Vcc (Supply Voltage)
12	Vcc (Supply Voltage)
13	Vee (Ground)
14	Data In
15	Data In (Inverted)
16	No Connection ^(Note)

Receiver Pin Assignment

Pin No.	Description
1	No Connection ^(Note)
2	Data Out (Inverted)
3	Data Out
4	Vcc (Supply Voltage)
5	Vcc (Supply Voltage)
6	Vcc (Supply Voltage)
7	Vee (Ground)
8	No Connection ^(Note)
9	No Connection ^(Note)
10	No Connection
11	Vee (Ground)
12	Vee (Ground)
13	Vee (Ground)
14	SD
15	/SD
16	No Connection ^(Note)

Note : Metal case version Pin1, Pin8, Pin9 and Pin16 internal connect to case.

Multi-mode 155Mbps Transmitter / Receiver

Outline Drawing (2X10 Pins Package)

2X10 Pins Metal Case :

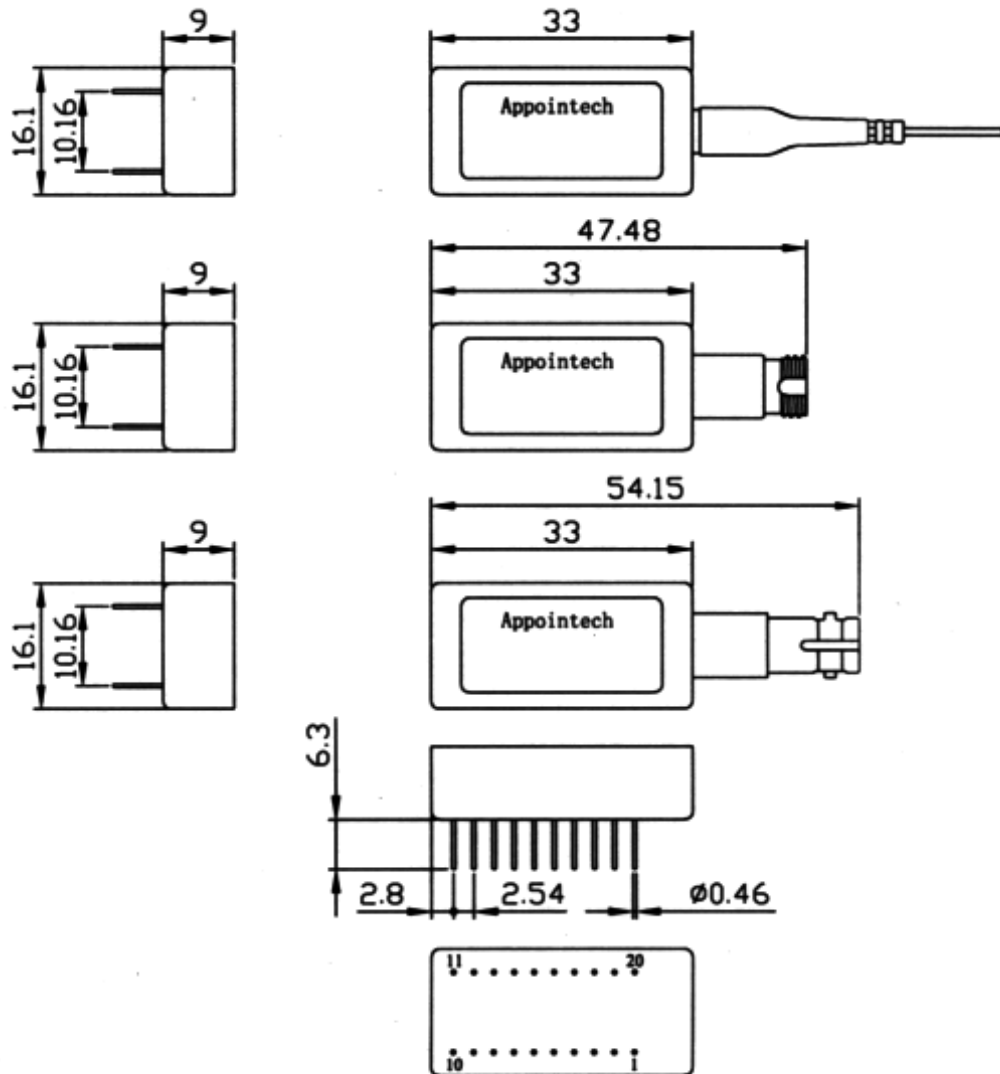

UNIT : mm

Multi-mode 155Mbps Transmitter / Receiver

Pinout Description (2x10 Pins Package)

Transmitter Pin Assignment

Pin No.	Description
1	No Connection
2	No Connection
3	No Connection
4	No Connection
5	Vee(Ground)
6	Vcc(Supply Voltage)
7	Transmitter Disable ^(Note)
8	Vcc(Supply Voltage)
9	Vcc(Supply Voltage)
10	No Connection
11	Vee(Ground)
12	Vcc(Supply Voltage)
13	Vee(Ground)
14	Vee(Ground)
15	Data In (Inverted)
16	Data In
17	No Connection
18	Vcc(Supply Voltage)
19	No Connection
20	No Connection

Receiver Pin Assignment

Pin No.	Description
1	No Connection
2	No Connection
3	No Connection
4	No Connection
5	No Connection
6	Vee(Ground)
7	Data Out
8	Vee(Ground)
9	Data Out (Inverted)
10	No Connection
11	Vcc(Supply Voltage)
12	SD
13	Vee(Ground)
14	/SD
15	Vee(Ground)
16	Vee(Ground)
17	No Connection
18	No Connection
19	No Connection
20	No Connection

Note : Input TTL Logic Low Level to Switch Laser "ON".
 Input TTL Logic High Level to Switch Laser "OFF".

Appointech, Inc.

6F-2, NO.192 Tung-Kuan Rd.,
 Hsinchu, Taiwan, R.O.C.
 TEL : 886-3-573-8478
 FAX : 886-3-573-8441
 E-mail : sales@appointech.com
<http://www.appointech.com>